

# INSTRUCTIONS FOR

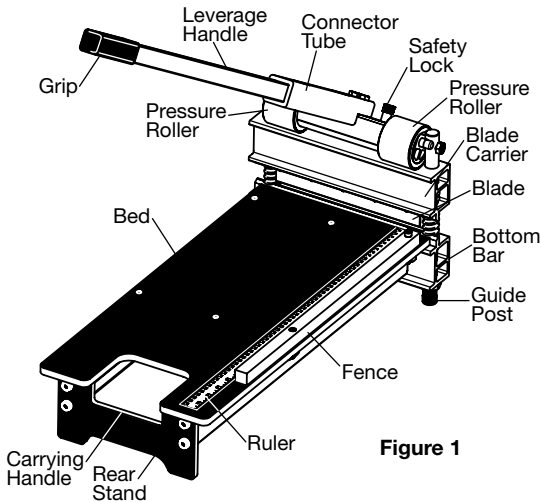

Figure 1

WARNING!



KEEP HANDS  
AWAY FROM:

BLADE  
BLADE CARRIER  
PRESSURE ROLLERS



## NO. 679 9" WOOD CUTTER

### SAFETY FIRST:

The Crain 9" Wood Cutter is designed to cut wood and laminate flooring planks only. It is not designed for cutting shingles or wall siding. Do not use this cutter for any purpose not described in this manual. Read and save all instructions.

This cutter has a sharp blade. Keep hands away! The blade is lever-activated and can cause severe cuts or sever fingers or hands. Pay attention to the position and motion of the blade in operation and transportation of the cutter.

If the material being cut gets stuck on the blade, remove the stuck material from the blade using scrap material or other tool. Do not use bare hands! Keep hands away from the blade at all times. Use of new, clean, sharp blades can reduce the sticking of materials on the blade.

Scrap materials, dust, and splinters can accumulate around the blade, behind the blade, or on the bed of the cutter. These can impair the safe operation of the cutter. Keep these clear at all times by dusting them off using a piece of scrap material or other tool. Keep hands away from the blade.

The cutting operation may leave splinters or sharp edges on the material that

is being cut. Some materials may require sanding before final installation. Inspect all cuts prior to installation. Do not install cut pieces with splinters or sharp edges. Keep splinters and cut pieces with sharp edges out of the work area.

This cutter has two pressure rollers that can pinch and crush fingers or hands. Keep hands away!

Keep fingers and hands out from underneath the blade carrier, as these can be crushed against the material being cut, or against the bed of the cutter.

The cutter has a safety lock that holds the leverage handle and the blade in the down position. For protection, lock the safety lock whenever the cutter is not in use. Also, lock the safety lock whenever the cutter is being transported or placed in storage. To lock the safety lock, move the handle to the down position, then slide the safety lock to the far right (Figure 3). When the safety lock is locked, tighten the safety lock's lock nut to fix the safety lock in locked position.

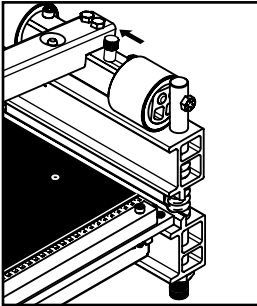

**Figure 2 - Unlocked**

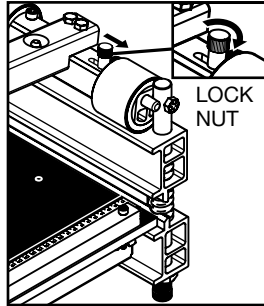

**Figure 3 - Locked**

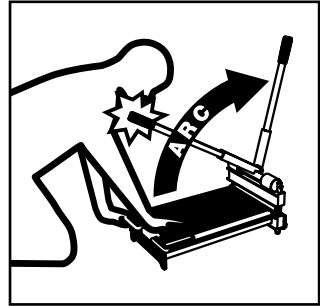

**Figure 4**

This cutter has a spring-loaded leverage handle that rises automatically with enough force to cause injury (Figure 4). Be aware of the motion of the leverage handle. As it rises, guide the leverage handle to its starting upright position to prevent it from slamming against its stop or impacting your body. In operation, kneel to the side of the leverage handle, keeping your head and the rest of the body out of its arc, and keep bystanders out of the way.

Wear eye and ear protection when using this cutter.

This cutter is not to be used by children or persons with reduced physical, sensory or mental ability, or that lack experience and knowledge, unless they have been given supervision or instruction.

Keep the work area clean. Clutter invites accidents. The work environment should be clean, dry, well lit, and clear of any flammable materials or explosive gasses. Do not use the cutter in wet or damp conditions.

Keep children and bystanders away from the cutter and out of the work area.

This cutter is a flooring tool for use on the floor only. It has a spring-loaded leverage handle that generates a lot of force and can cause motion such as tipping of the cutter. Do not use the tool on a table that can tip and cause the cutter to fall, or anywhere near stairs or balconies from which it may fall.

Keep blades clean and sharp. Dull blades can require excessive cutting force, which may result in increased risk of injury, or damage to the tool.

**CAUTION:** Do not apply excessive force to the cutter, as this can cause injuries, including back injuries, and can damage the cutter. Do not alter the cutter by using attachments such as extended leverage handles or other power sources. Damage or injury may result. Use only Crain replacement blades designed for use with this cutter.

Some dust created by cutting contains chemicals that can be injurious to your health, including formaldehyde. Work in a well-ventilated area, and work with approved safety equipment. If necessary, wear a dust respirator mask or a dual filter (dust and fume) respirator mask which has been approved by the Occupational Safety and Health Administration (OSHA), the National Institute of Safety and Health (NIOSH), or the United States Bureau of Mines. These masks and replaceable filters are readily available at major hardware stores. Be sure the mask fits. Beards and facial hair may keep masks from sealing properly. Change filter often. Disposable paper masks are NOT adequate.

**CAUTION:** Tool is heavy! Users with adequate strength should move the cutter with proper lifting technique and constant awareness of the sharp blade. Be careful not to drop the machine on feet or other body parts. Carry the cutter by its carrying handle (Figure 1). Do not carry the cutter by the leverage handle, the blade carrier, or bottom bar. Keep hands away from the blade!

Store the cutter out of reach of children, with the safety lock in the locked position (Figure 3). Store the cutter in a safe location that prevents the cutter from falling and causing possible injury.

## **OPERATION:**

**MATERIALS THAT CAN BE CUT:** This cutter is designed to cut wood and laminate plank floor materials up to ¾" thick **one plank at a time**.

Some of these materials may require excessive force to be cut, resulting in possible damage to the cutter, or injury to the user. This depends on the hardness of the material, grain structure, thickness of the laminate or other wear layer (veneer), the width of the board, or a combination of these factors. In general, if the leverage handle develops significant bend and the blade is not cutting through the material, the cutter should not be used on that material. **WARNING:** Do not attempt to cut materials that require excessive force. Injuries including back injury may occur. **Damage to the leverage handle voids the cutter warranty!**

In general, materials harder than red oak (Janka hardness of 1290), including white oak, most species of maple, cherry, mahogany, bamboo, hickory, pecan and most exotic hardwoods should not be cut with this cutter. Janka hardness ratings for most woods are available on the Internet. Laminate flooring with a high pressure wear layer should not be cut with the cutter. Engineered hardwood flooring with a wear layer greater than 2 mm should not be cut with the cutter. **Cutting excessively hard material chips and damages blades.**

**PREPARING TO CUT:** Place the cutter flat on the floor with its two guide posts and rear stand flat on the floor. In use, the cutter must be stable on the floor and prevented from rocking or tipping. Make sure there is space around the cutter for handle travel (Figure 4). Check that the blade is sharp and free of burrs (for instructions on removing burrs, see MAINTENANCE below).

**ASSEMBLE THE LEVERAGE HANDLE:** This cutter is designed to be powered manually using the leverage handle that is provided. Do not add additional leverage handles or other power sources to the cutter.

To assemble the leverage handle, insert it into the connector tube on the blade carrier (Figure 5). The leverage handle includes a spring-loaded button that engages one of the two holes in the connector tube. In normal operation, the leverage handle is engaged in the upper hole for increased leverage. In transportation or storage, slide the leverage handle inward and engage the button in the lower hole.

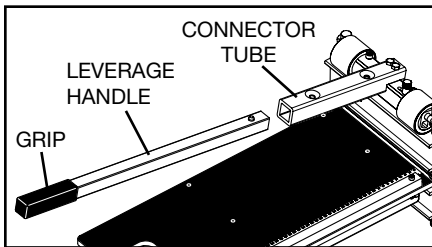

Figure 5

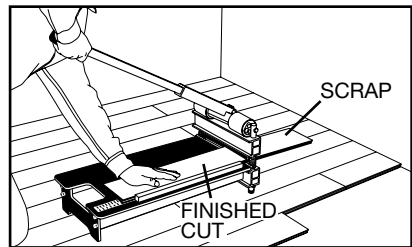

Figure 6

**DISENGAGING THE SAFETY LOCK:** Grasp the leverage handle at the grip to control its motion. Loosen the safety lock's lock nut, then slide the safety lock all the way to the left to disengage (Figure 2). Tighten the safety lock's lock nut to hold it in the disengaged position. The leverage handle is spring loaded and will rise automatically. In operation, keep a hand on the grip of the leverage handle to keep it under control.

**MAKING CUTS:** Place the material to be cut on the bed of the cutter and slide it against the fence (see below and Figure 7) and beneath the blade. Keep hands away from the blade and out from under the blade carrier. Note that the blade produces the cleanest edge from its inner (bed facing) edge surface only. The cut piece remaining on the bed will be the finished cut, and the piece beyond the blade will be scrap (Figure 6).

To assist in producing the desired length of cut, the bed of the cutter includes

a ruler in both inches and metric units. The ruler measures the distance from the inner edge surface of the blade, indicating the length of finished cut.

Push down on the leverage handle with one hand, keeping the other hand on top of the material being cut. (See Figure 6.) **HAND PRESSURE** should be used to power the cutter, not foot pressure, body weight, other weight, or impact on the leverage handle. Keeping a hand on the material prevents it from moving and ensures an accurate cut. Keep hands away from the blade, blade carrier, and pressure rollers at all times, and keep hands out from under the material being cut. Stay alert and watch the cutting process at all times.

Continue pushing the leverage handle until the material is cut, then raise it with a hand on the grip and the assistance of the springs. Do not allow the handle to rise rapidly and slam against the stop. Injury or damage may result.

After the cut, the material being cut may become stuck on the blade. Remove the stuck material from the blade using scrap material or other tool. Do not use bare hands!

Prevent build-up of scrap, splinters and dust around the blade, blade carrier, and on the cutting bed. Dust off using a piece of scrap or other tool.

Check the cut edges of any material that will be installed for splinters or sharp edges. These may require removal by sanding or trimming to prevent injury.

The fence of the cutter is movable to any one of three straight positions (Figure 7). Moving the fence helps position the material being cut under different areas of the blade, so that as areas of the blade become dull, other areas that are still sharp can be more easily used. Cutting under different areas of the blade also wears the sides of the cutter mechanism more evenly over time, extending the life of the tool. Cutting mostly under one side can wear out the cutter sooner.

To move the fence, remove the two wing nuts from beneath the bed, and remove the fence. Insert the fence into any pair of holes as shown in Figure 7, then reattach and tighten the wing nuts.

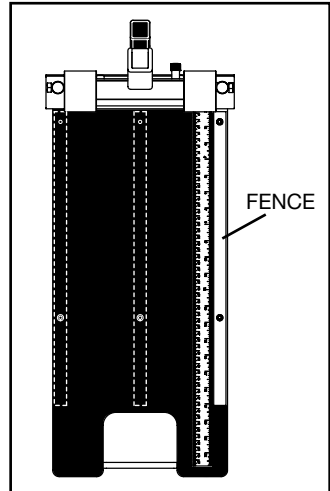

Figure 7

## **TRANSPORTATION AND STORAGE:**

Whenever the tool is left unattended, or during transportation or storage, the safety lock should be locked (Figure 3). The safety lock lowers the blade to shield it from contact, and prevents unexpected motion of the leverage

handle. To lock the safety lock, lower the leverage handle to its bottom position and slide the safety lock all the way to the right. The safety lock includes a lock nut that should be tightened down to prevent accidental unlocking.

For transportation or storage, the leverage handle should also be positioned with its button in the lower hole of the connector tube.

Carry the cutter by its carrying handle (Figure 1). Do not carry the cutter using its leverage handle, blade carrier, or bottom bar. Keep hands away from the blade, blade carrier, and pressure rollers at all times.

When transporting or storing the cutter, use caution to prevent the cutter from being dropped or falling. Damage to the cutter or injury may result.

In transportation or storage, do not pile heavy materials on top of the tool such as by putting it in the bottom of the van and piling up flooring and other materials on top of it. Damage to the cutter's bed and mechanism may result.

## MAINTENANCE:

**BURRS OR NICKS ON BLADE:** Burrs or nicks may develop on the inner (bed facing) side of the blade that can cause the blade to seem dull and cut less efficiently. A sharpening stone is available (Part No. 1675-28) for restoring the edge as much as possible (Figure 8), but is NOT INCLUDED WITH THIS CUTTER. Any standard sharpening stone, preferably one with one side coarse and the other side fine, may also be used.

To use a sharpening stone on the blade, there is no need to remove the blade from the blade carrier. Simply raise the leverage handle to raise the blade enough distance for adequate clearance of the stone, then lay the wide side of the stone against the inner face of the blade. NOTE - the stone is two-sided: coarse and fine. Use the coarse side for large burrs or nicks, and the fine side for smaller ones. Move the stone back and forth from end to end of the blade. Use caution not to rub the anvil of the cutter with the stone, or undue wear may result. The stone should contact the blade only. Use caution not to touch the blade as it will cut fingers or hands.

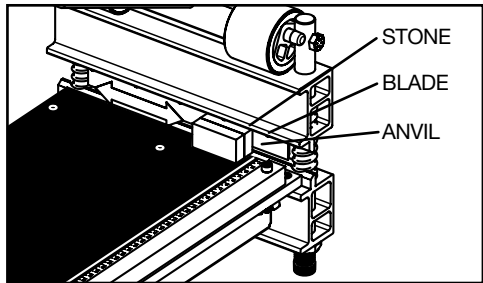

Figure 8

**CHANGING THE BLADE - WARNING:** The blade is extremely sharp, and it can be slippery and difficult to hold. Use extreme caution! The use of gloves is recommended. To remove and replace the blade, first remove the leverage handle, fence, and cut guide. Turn the cutter upside down and place the bed

flat on a large, stable surface such as a solid table that will not tip or move (Figure 9). Turning the cutter upside down ensures the blade will rest on the blade carrier during the process due to gravity, and prevents the blade from unexpectedly falling off. Move the connector tube to the top of its travel. This increases the space between the blade and the anvil and creates room to work.

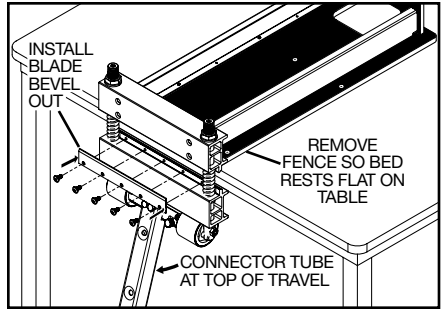

Figure 9

Remove the 5 blade screws using a Phillips screwdriver. Hold the blade against the blade carrier when removing the last screws by contacting a flat surface of the blade body away from the sharpened edge. When removing a blade or installing a new blade, it is advisable to hold it by its sides.

When installing a new blade, it must be installed with the edge up and the bevel out in relation to the bed. Be sure the blade carrier is cleared of all debris before installing the blade. Fasten the blade to the carrier with the five blade screws.

**WARNING:** Some dust created by power sanding, sawing, grinding, drilling, and other construction activities contains chemicals known to the State of California to cause cancer, birth defects or other reproductive harm. Some examples of these chemicals are:

- lead from lead-based paints,
- crystalline silica from brick, cement and other masonry products, and
- arsenic and chromium from chemically-treated lumber.

Your risk from these exposures varies, depending on how often you do this type of work. To reduce your exposure to these chemicals: work in a well-ventilated area, and work with approved safety equipment, such as those dust masks that are specially designed to filter out microscopic particles.

**REPLACEMENT PARTS:**

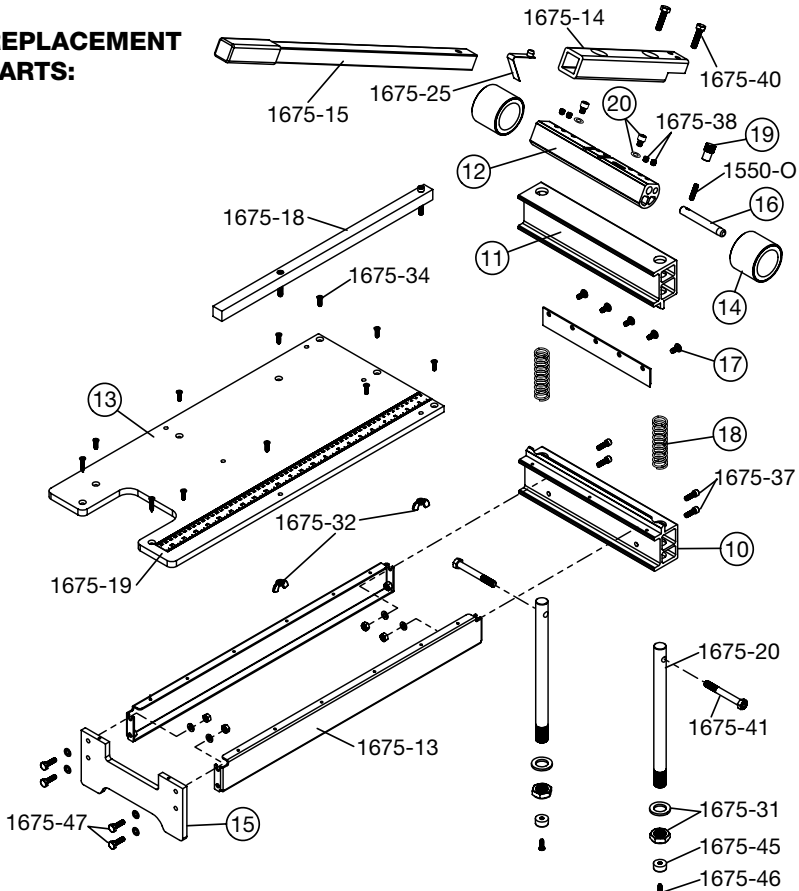

Order #	Description	Order #	Description	Order #	Description	
1679-10	Bottom Bar	1679-20	Pressure Roller Set Screws (4)	1675-32	Fence Wing Nut Screw Set (2)	
1679-11	Blade Carrier	Parts common to the No. 675:			1675-34	Bed Fastener Set (13)
1679-12	Crankshaft	1675-13	Bed Support (1 only)	1675-37	Bed Support Fasteners (4)	
1679-13	Bed	1675-14	Connector Tube	1675-38	Crankshaft Set Screws (4)	
1679-14	Pressure Roller (1 only)	1675-15	Leverage Handle	1675-40	Connector Tube Screws (2)	
1679-15	Rear Stand	1675-18	Fence	1675-41	Crankshaft Pivot Bolts (2)	
1679-16	Safety Lock Bar	1675-19	Ruler Label	1675-45	Guide Rod Foot (1)	
1679-17	Blade Screw Set (5)	1675-20	Guide Rod (1 only)	1675-46	Guide Rod Foot Screw (1)	
1679-18	Compression Spring Set (2)	1675-25	Spring Clip	1675-47	Rear Stand Fasteners (6)	
1679-19	Safety Lock Thumb Screw	1675-31	Adjustment Nut & Washer	1550-0	Set Screw (Safety Lock Bar)	

02/2017

**GUARANTEE**

This No. 679 9" Wood Cutter is guaranteed to be free of defects in workmanship or quality of materials for a period of ONE YEAR. Any parts of tools found defective subject to the guarantee will be provided at no charge. Credit in full or part cannot be extended by the distributor. New tools will not be given as replacements for those pending a warranty adjustment. All merchandise returned subject to this warranty must be accompanied with same. All merchandise returned must be shipped freight prepaid to CRAIN CUTTER CO., INC. ("Crain"), and must be in complete assembled units. No consideration will be given to unassembled parts. All disputes will be up to the consideration of Crain and their decision will be final.