

INSTRUCTION MANUAL FOR

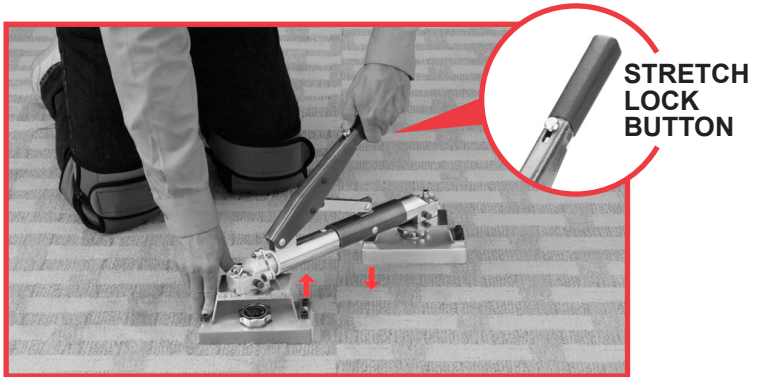

PATTERN MATCHING WITH PIVOTING GRIPPER HEADS



CRAIN

**No. 515 Mini-Stretcher
with Seam Repair Attachment**

CRAIN NO. 515 MINI-STRETCHER FEATURES

STRETCH LOCK BUTTON:

The stretch lock button (Figure 1) holds a stretch. This frees up your hands for tucking or seam repair work. You can lock the stretcher at any point by pushing the locking button forward to the position marked "LOCK". To release the lock, pull the button back to the upper position. The leverage handle also locks at the bottom of its downward movement.

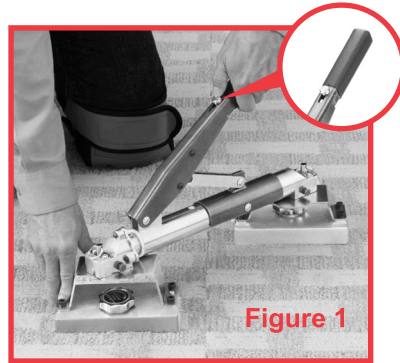

QUICK-CHANGE PUSH BUTTONS:

As shown in Figure 2, both ends of the tool have sockets with quick-change push buttons to install either A.) two gripper heads, or B.) one gripper head and a wall blade. Depress a push button, and the pin on the gripper head or wall blade can be inserted into or removed from the socket. Release the push button with the pin fully inserted in the socket, and the pin will lock in place.

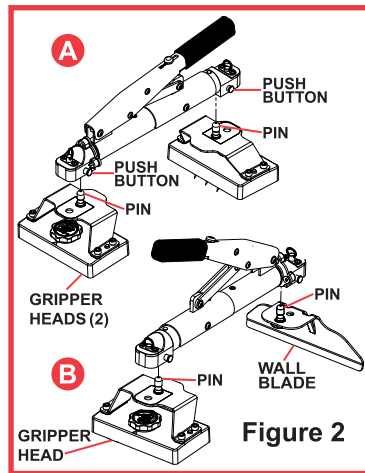

DUAL PIVOTS & PIVOT LOCK PINS:

The gripper heads or wall blade will pivot when installed on either end (Figure 3), or they can be locked if desired. The gripper heads can be pivoted parallel to the seam for pattern matching work (Figure 1). The gripper heads and tail blade can be locked perpendicular to the tubes by depressing the pivot lock pins on either end of the tool (Figure 3).

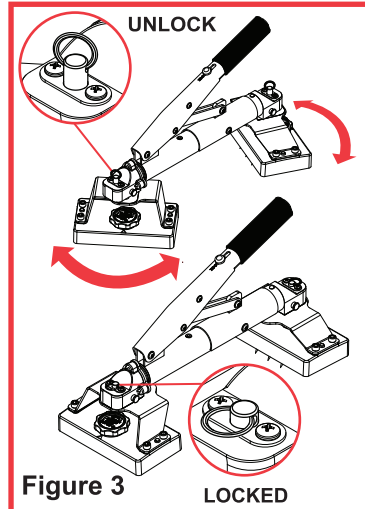

GENERAL USAGE:

The Mini-Stretcher works by pulling the rear gripper head towards the front, when the leverage handle is lowered (Figure 4).

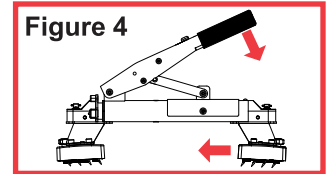

PATTERN MATCHING USAGE

Attach gripper heads on both ends (Figure 5).

Set the pin depth on both gripper heads using the dial. The pins should penetrate into the carpet's backing, but not through the backing, or damage to the carpet may result. Turn clockwise for greater pin depth penetration, or counterclockwise for reduced penetration.

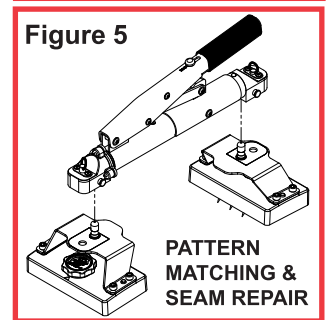

For pattern matching work, the Mini-Stretcher can be used for either "CRAB WALKING" (Figure 6) one side of the carpet seam at a time, or "DIAGONAL STRETCHING" (Figure 1) which pulls both sides of the seam inwards simultaneously.

CRAB WALKING:

Place the Mini-Stretcher in the middle of the seam, and on one side of the seam (Figure 6). **Step 1:** raise the leverage handle to maximum height, anchor the grippers in the carpet, then lower the leverage handle. This forms a hump of carpet between the grippers. **Step 2:** place Mini-Stretcher in front of the hump just created, and repeat. Steps 1 & 2 gradually pull the carpet forward, bringing that side of the carpet into alignment with the other side. At the end of the seam, return to the middle and work in the opposite direction to bring the entire seam into alignment.

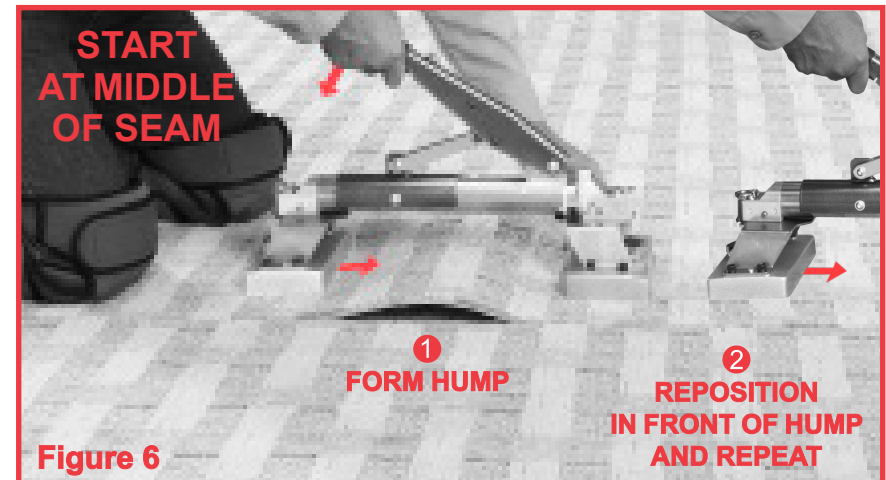

DIAGONAL STRETCHING:

Diagonal stretching (Figure 7) across the seam can help with smaller adjustments, particularly correcting edge deviation or closing gaps. The dual pivoting grippers can be positioned at different angles as desired to pull the seams together at the angle that produces the right adjustment.

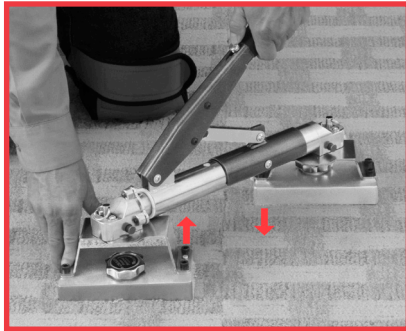

Figure 7

PATTERN MATCHING PRO TIPS:

Cuts should be arranged so the longest pattern is installed first. Dry lay the carpet prior to applying adhesive. Pre-stretch the carpet only enough to match the pattern fairly closely, but do not attempt final alignment. For final pattern alignment, apply adhesive to the subfloor with the proper notched trowel, but apply only to those areas on either side of the seam being presently aligned, so that alignment can be achieved before adhesive tacks up. Set the carpet into the wet adhesive, then stretch into final alignment. The use of stay nails is required to hold the carpet in place until the adhesive is fully cured.

SEAM REPAIR USAGE:

Install both gripper heads on the tool as shown in Figure 5, and set pin depth so that the pins extend into, but not through, the carpet's backing.

To open a seam for repair, place the gripper heads on either side of the seam, with each head oriented parallel to the seam (Figure 8). For this usage, it can be helpful to lock the gripper heads perpendicular to the leverage handle using the pivot lock pins (Figure 3). Lower the leverage handle to pull the seam edges together to open the seam as needed.

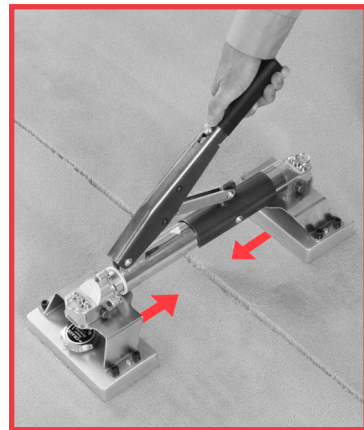
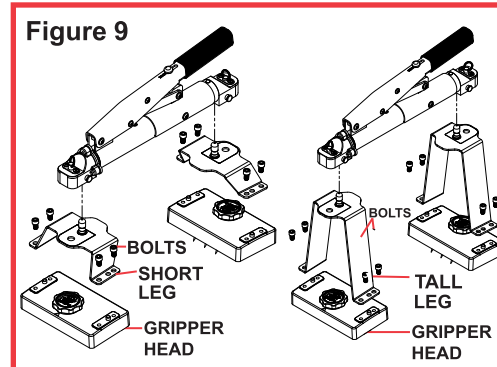

Figure 8

Once the seam is opened, you can cut apart the portion requiring repair and apply latex or other form of adhesive to perform repairs as necessary. It is usually advisable to re-seal seam edges to prevent unraveling, delamination, or loss of tufts. Allow adhesive to fully cure before removing the tool. Otherwise, it is necessary to use stay nails.

SEAM REPAIR WITH A SEAMING IRON:

Tall seam repair legs are available as an accessory (Crain No. 519) to allow a carpet seaming iron to pass underneath the tool more conveniently (Figure 10). To install the tall seam repair legs on both ends, depress the quick-change push button on either end, and remove both gripper head and short leg assemblies (Figure 9). Using the provided hex wrench, unscrew the four bolts, and remove the short legs from the gripper heads. Attach the tall seam repair legs to each of the gripper heads using the same four bolts. Depress the quick-change push button on either end to reinsert the tall leg pins in the sockets, and release push button to lock.



SHORT LEGS
DISASSEMBLY

TALL LEGS
ASSEMBLY

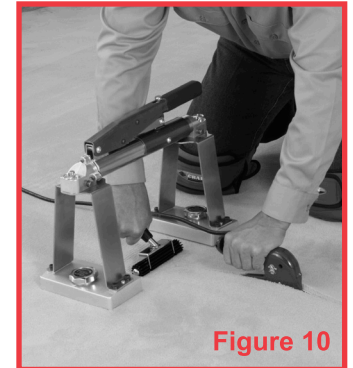

Figure 10

SEAM IRON GOES UNDER
WITH TALL LEGS

STRETCHING CARPET:

The Mini-Stretcher is convenient for removing undesired humps that may be present in improperly installed carpet.

NOTE: installing an extra row of strip in front of the existing row is normally required for reinforcement of the tack strip.

As shown in Figure 11, install the wall blade on the front end of the tool (nearest the leverage handle). Insert the wall blade behind the carpet and the tack strip (Figure 12). Lower the leverage handle to stretch the carpet.

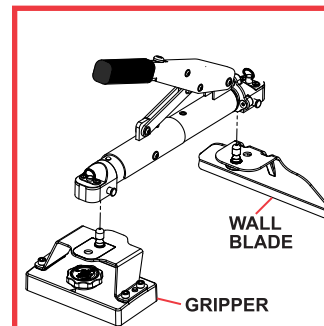

Figure 11

STRETCHING ASSEMBLY

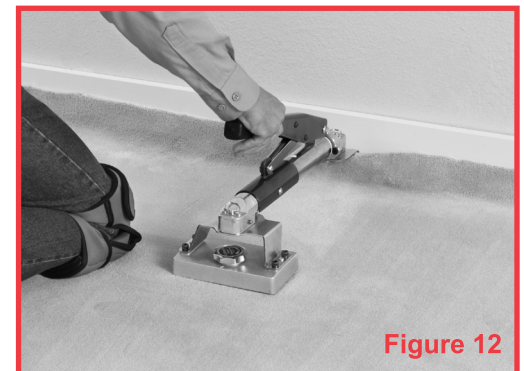
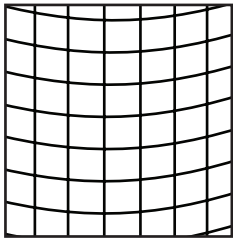

Figure 12

STRETCHING CARPET

TYPES OF PATTERN CARPET DISTORTION:



BOW

A visible distortion or wave of the pattern across the width.

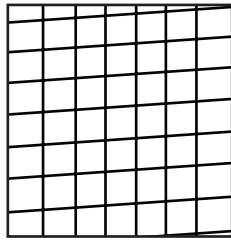

SKEW OR BIAS

The pattern is not square with either edges.

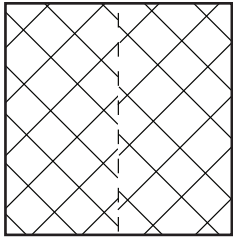

ELONGATION

Increase or decrease of cumulative pattern measurements, one breadth of carpet to next.

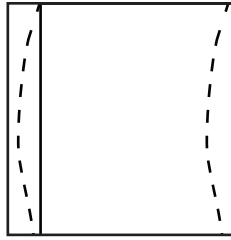

EDGE DEVIATION

A visible wavy or crooked pattern, running parallel from the edge of the carpet.

TOLERANCES: although individual manufacturers have tolerances to which their patterned products must conform, **THERE ARE NO INDUSTRY STANDARDS FOR CARPET PATTERN VARIATION.** Call the carpet manufacturer for their tolerances. Note: do not install carpet if a defect is visible, or if the distortion exceeds the tolerances specified by the carpet manufacturer.

REPLACEMENT PARTS NO. 515 MINI STRETCHER

ORDER #	DESCRIPTION
No. 519	Tall Seam Repair Legs
1515-10	Outside Tube Assembly
1515-11	Inside Tube Assembly
1515-12	Short Leg w/Pin
1515-14	Pin Plate Housing
1515-15	Pin Plate
1515-16	Gear Assembly
1515-18	Handle Bushing w/Fasteners (2)
1515-19	Gear Assembly Bushing w/Fasteners (2)
1515-20	Leverage Handle
1515-21	Leg Bolts Set (4)
1515-23	Wall Blade w/Pin
1515-24	Release Pin w/Spring & Lock Ring
1515-26	Pivot Lock, Ring & Fast. (4)
1515-28	Bushing w/Fasteners (2)
1515-30	Thruster Slide
1515-31	Thruster Slide Bushing w/Fasteners (2)
1515-32	Stretch Lock Spring
1515-33	Carrying Case (not shown)
1515-35	Inside Tube Assembly Sleeve
1515-36	Hex Key
1500-5	Nylon Bearing Set (2)
1500-6	Dog
1500-8	Lock Button w/Fasteners (3)
TWO PACKS OF THE FOLLOWING ARE REQUIRED FOR REPLACEMENT TO EITHER GRIPPER (4 TOTAL BOTH GRIPPERS):	
1505-K	Gripper Insert (3)
1505-Q	Gripper Screws (3)

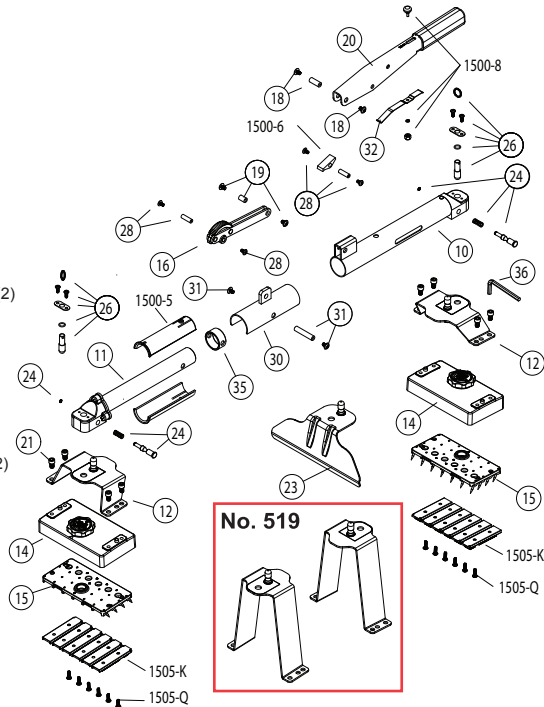

Please fill out and mail this card to validate your **CRAIN** guarantee.

NAME _____

ADDRESS _____

CITY _____

STATE _____ ZIP _____

**TOOL PURCHASED:
#515 Mini-Stretcher**

PURCHASED FROM: _____

DATE PURCHASED: _____

PLEASE CHECK:

INDIVIDUAL FLOORING INSTALLER

WORKROOM

FLOORING DEALER

INSTALLATION CONTRACTOR

OTHER _____

CRAIN WARRANTY

This Crain No. 515 Mini-Stretcher is guaranteed to be free of defects in workmanship or quality of materials for a period of **ONE YEAR.**

Any parts of tools found defective subject to guarantee will be replaced at no charge. Credit in full or part cannot be extended by the distributor. New tools will not be given as replacements for those pending a warranty adjustment.

All merchandise returned subject to this warranty must be accompanied with same. All merchandise returned must be shipped F.O.B. Milpitas, California, and must be in complete, assembled units. No consideration will be given to unassembled parts. All disputes will be up to the consideration of **CRAIN CUTTER CO., INC.** and their decision will be final.

PLACE
STAMP
HERE

Crain Cutter Co., Inc.
1155 Wrigley Way
Milpitas, CA 95035-5426